



**Oldcastle** BuildingEnvelope™

***STANDARD DOOR and FRAME***  
***INSTALLATION AND GLAZING MANUAL***

*Note: Installation and Glazing Manuals are product specific. **FOR REVIEW ONLY!***

## CONTENTS

Inspect Materials .....	Page 3
Door Size Warranty Guidelines .....	Page 4
Standard Hardware Locations .....	Page 5
Door Handing Designations .....	Page 6
Glass Sizing	
For Doors .....	Page 7
For Sidelights .....	Page 8
Preparation of Opening .....	Page 9
Preparation of Frame .....	Page 10
Installation of Frame .....	Page 11
Installation of High Performance Threshold .....	Page 12
Threshold Modification .....	Page 14
Glazing the Door .....	Page 15-16
Installation of Offset Hung Door on Butt Hinges .....	Page 17-18
Installation of Offset Hung Door on Pivots .....	Page 19
Installation of Offset Hung Door with Standard Concealed Closers .....	Page 20
Installation of Center Hung Door with Standard Concealed Closer .....	Page 21
Installation of Offset Hung Door with LCN Concealed Closer .....	Page 22
Installation of Center Hung Door with LCN Concealed Closer .....	Page 23
Installation of Offset Hung Door with Floor Closer .....	Page 24
Final Adjustments to the Door .....	Page 25-26
Attachments of and Adjustments to Hardware .....	Page 27
Push Bar / Push Handle Installation .....	Page 28-29
Maintenance Recommendations .....	Page 30-31

## INSPECT MATERIALS UPON RECEIPT

Inspect all materials upon receipt to be sure that all items have been received and that no damage has occurred. If there is damage that is clearly due to improper handling in transit, it is up to Oldcastle BuildingEnvelope™ customer to settle claims with the freight company. If there is damage (or missing / incorrect items) due to a Oldcastle BuildingEnvelope™ error, please notify Oldcastle BuildingEnvelope™ within 7 days.

The following items are shipped in the door box:

- Assembled door with glass stops taped in place
- A box within the door box with the following items enclosed:
  - Push bar
  - Pull handle
  - Exit device (if required)
  - Pivots or butt hinges

The following items are shipped in the frame box:

- Left door jamb
- Right door jamb
- Door header
- Threshold
- Screws and clips; and gaskets (if required)
- Transom bar (if required)
- Transom head (if required)
- Transom sash (if required)

The following items are shipped in separate boxes:

- V-231 weatherstrip (if required)
- Closer

Doors and frames will be prepped for the following:

- Pivots or butt hinges or Pemko continuous hinge
- Push bar (if Oldcastle BuildingEnvelope™'s or in Oldcastle BuildingEnvelope™'s possession prior to fabrication)
- Latch end of exit device (when required)
- Concealed overhead closer (when required)
- Cylinder (when required)

If hardware is not by Oldcastle BuildingEnvelope™, physical hardware is required at Oldcastle BuildingEnvelope™ prior to fabrication of doors. Hardware may be prepped for by template; as long as the hardware supplier provides templates prior to fabrication (Note: Oldcastle BuildingEnvelope™ does not guarantee fit with actual hardware; Only that the prep was made per templates provided). Oldcastle BuildingEnvelope™ does not prep for surface applied hardware items. Pemko hinges are the only continuous hinges that Oldcastle BuildingEnvelope™ will prep for without physical hardware.

## DOOR SIZE WARRANTY GUIDELINES

The following is our standard warranty guidelines and recommendations for door sizes.

Doors with no muntins or muntins at least as large as D-11 (1 7/8"):	<u>Size Up To &amp; Including</u>
• Standard and Rugged Narrow Stile	4'0" x 8'6"
• Standard and Rugged Medium Stile	4'0" x 9'0"
• Standard and Rugged Wide Stile	4'0" x 10'0"
Doors with at least one D-135 (1/2") muntin:	
• Standard and Rugged Narrow Stile	3'0" x 7'6"
• Standard and Rugged Medium Stile	3'0" x 8'0"
• Standard and Rugged Wide Stile	3'0" x 8'0"
Auto Showroom Doors:	
• All types	5'0" x 8'0"
Any ASD leaf 5'0" x 8'0" or larger requires a caster on the leading edge.	
• Doors over 5'0" wide require butts or gear hinges. (No pivots)	

**NOTE:**

- All doors over 7'0" tall require a minimum of 1 1/2 pair of hinges or a continuous gear hinge. Ratio for intermediate hinges is one (1) for every 30" above 7'0".
- Doors utilizing special top and/or bottom rail assemblies, please contact Terrell.
- Doors over these sizes and requiring a warranty, please contact Terrell.

STANDARD HARDWARE LOCATIONS

CENTRAL & EASTERN REGION HARDWARE LOCATIONS

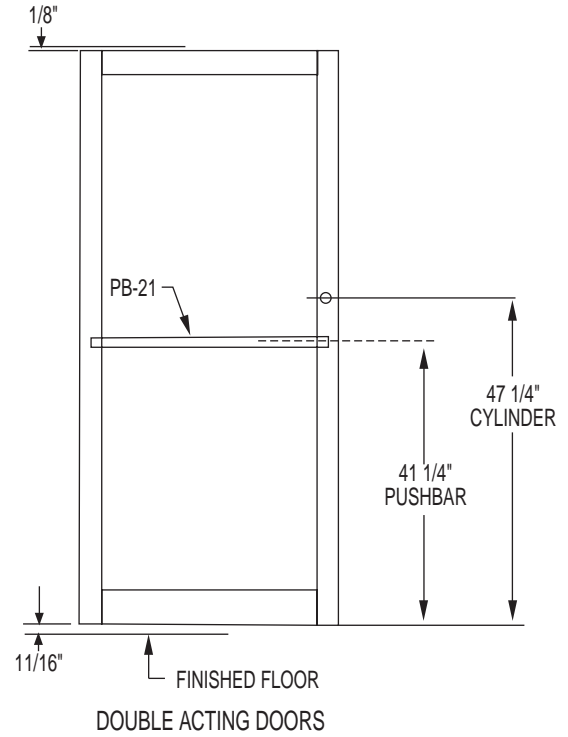
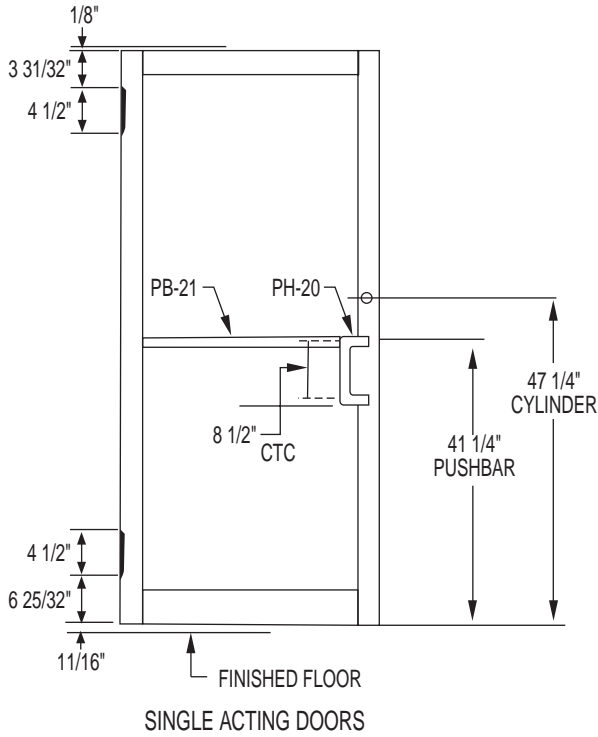

WESTERN REGION HARDWARE LOCATIONS

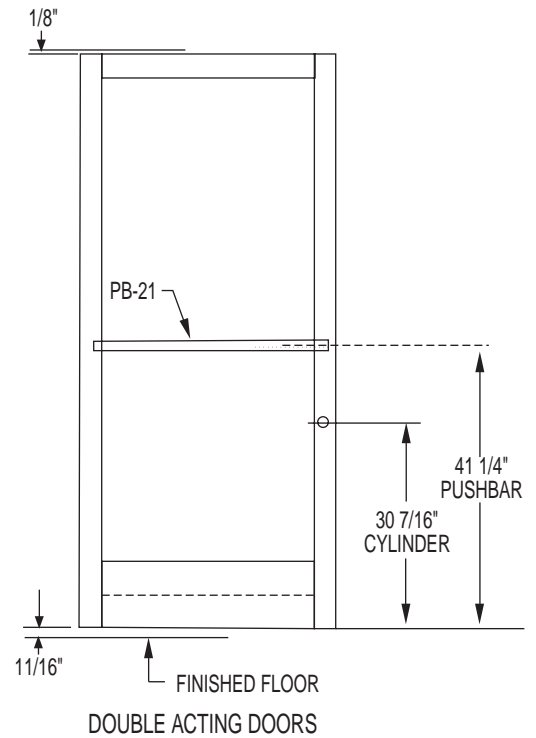
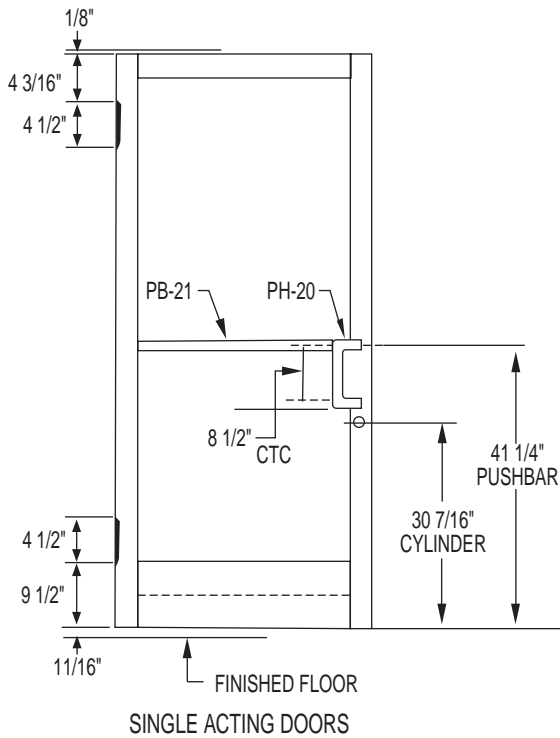

DOOR HANDING

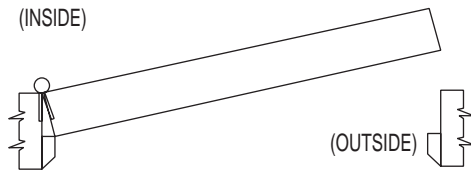

FOR HARDWARE: LEFT HAND, REGULAR (LH)  
**Oldcastle BuildingEnvelope™**  
 HINGED LEFT, SWING IN (HLSI)  
 SIMPLIFIED: LEFT HAND

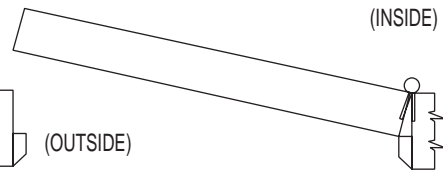

FOR HARDWARE: RIGHT HAND, REGULAR (RH)  
**Oldcastle BuildingEnvelope™**  
 HINGED RIGHT, SWING IN (HRSI)  
 SIMPLIFIED: RIGHT HAND

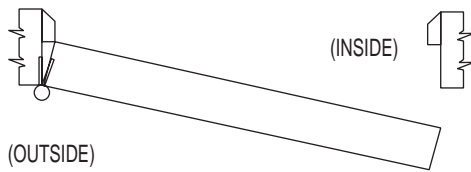

FOR HARDWARE: LEFT HAND, REVERSE BEVEL (LHR)  
**Oldcastle BuildingEnvelope™**  
 HINGED LEFT, SWING OUT (HLSO)  
 SIMPLIFIED: RIGHT HAND

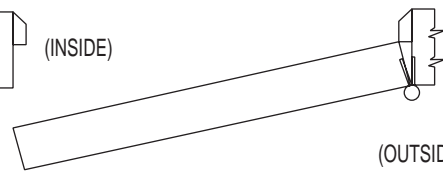

FOR HARDWARE: RIGHT HAND, REVERSE BEVEL (RHR)  
**Oldcastle BuildingEnvelope™**  
 HINGED RIGHT, SWING OUT (HRSO)  
 SIMPLIFIED: LEFT HAND

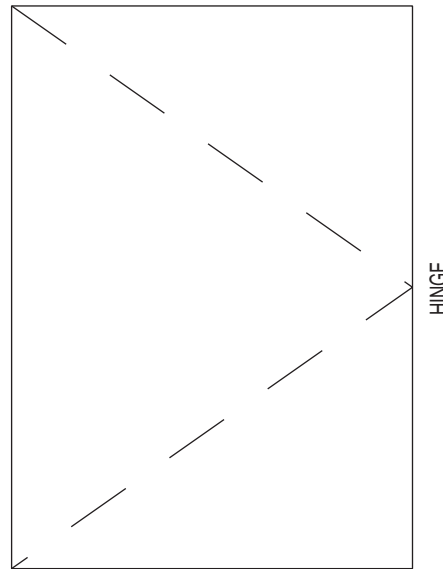
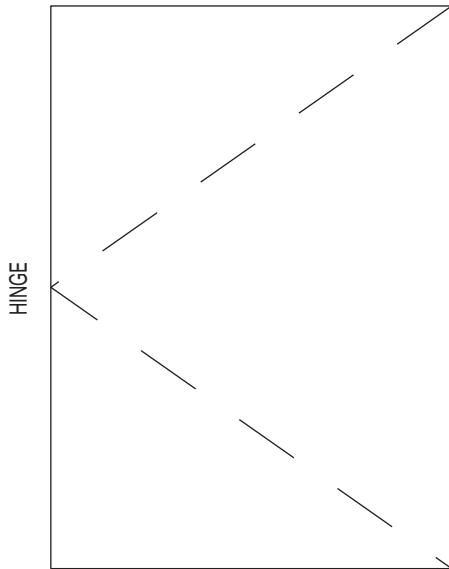

ELEVATIONS FROM EXTERIOR OF DOORS, SHOWING SWING.  
 ARROWS POINT TO HINGE SIDE.

DHI definition of hardware (door) handing:

The HAND of doors is determined from the outside of the door. The outside of a cupboard, bookcase, etc., is the room side. The outside of entrance doors is the weather side.

If standing outside of a door (facing the door), the butts are on your right, it is a LEFT HAND DOOR; if on the left it is a RIGHT HAND DOOR. If the door opens FROM you (is pushed open) it is a REGULAR BEVEL; if it opens TOWARD you (is pulled open) it is a REVERSE BEVEL door.

## GLASS SIZING

Door lites are calculated as follows:

Standard doors with no muntins should be calculated using the formulas and standard sizes shown in the Oldcastle BuildingEnvelope™ price catalog.

Non-standard doors are calculated as follows:

Metal to Metal (glass opening) minus 7/16" for 1/4" glazing or 9/16" for 1" glazing. Doors with muntins will be calculated using openings between muntins and rails/stiles as shown.

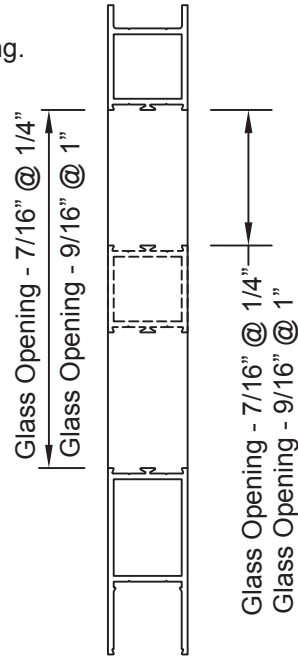
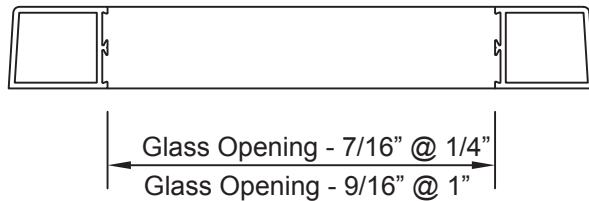

Transom Lites are calculated as follows:

FG-1000 / FG-2000 framing:

Horizontally:  
D.L.O. + 5/8"

Vertically:  
Without concealed closure:  
D.L.O. + 5/8"  
With concealed closure:  
DLO (frame = horiz to horiz) - 1 1/8" (sash) + 5/8"

FG-3000 framing:

Horizontally:  
D.L.O. (frame) - 1 1/2" (sash) + 5/8" (glass bite)

Vertically:  
Without concealed closure:  
D.L.O. + 7/8"  
With concealed closure:  
DLO (frame = horiz to horiz) - 3/4" (sash) + 7/8" (glass bite)

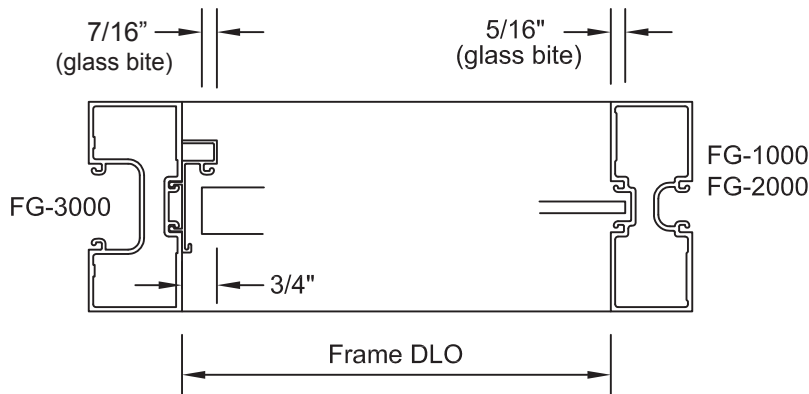
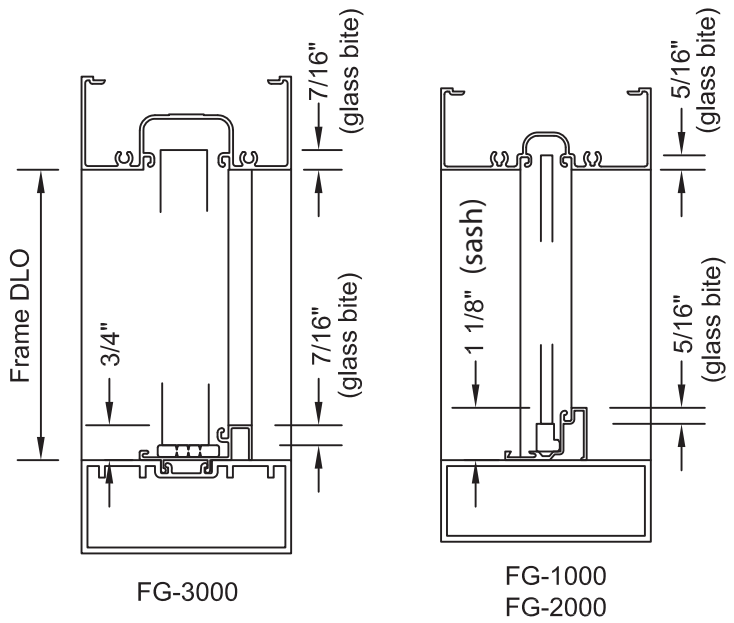

FG-1000 / FG-2000 use sash S-52 / S-53  
FG-3000 use sash FG-3157 / FG-3158

## GLASS SIZING

Sidelight framing glass sizes should be determined by the following:

<u>System</u>	<u>Formula</u>
FG-1000/2000	DLO +5/8"
FG3000	DLO +7/8"
S-52/S-53 or 54	Sash-to-sash DLO + 3/4"
TG	Sash-to-sash DLO + 7/8"



## PREPARATION OF OPENING

Prior to installation of a door and frame, it is important to consider your surrounding construction.

Is the opening large enough to handle the door and frame that was ordered?

Allow for at least 1/4" shim space all around.

Are there any obstructions present within the opening?

Is there sufficient structure to anchor the frame?

Is the support located in the proper position?

What is the sill condition?

Is there a ledge?

Is there enough space to get anchorage into floor slab?

If floor closer used, is the concrete blocked out at closer location?

Is there a need for a different style of threshold?

Be sure that the slab is level at door area.

Thresholds will be standard 4" wide, 1/2" tall; sloped front and back, unless otherwise noted.

If there is a problem with location of opening or slab level, please contact your general contractor, in writing, requesting a correction. DO NOT begin installation until problems are resolved.

When all items above are addressed satisfactorily, the installation process can begin.

### FLOOR SLAB SLOPE GUIDELINES

In order to insure proper operation and drainage of water from face of door, the substrate at the exterior of door must slope at a minimum of 1 degree. If substrate slopes upwards door will not open and water will flow into the building.

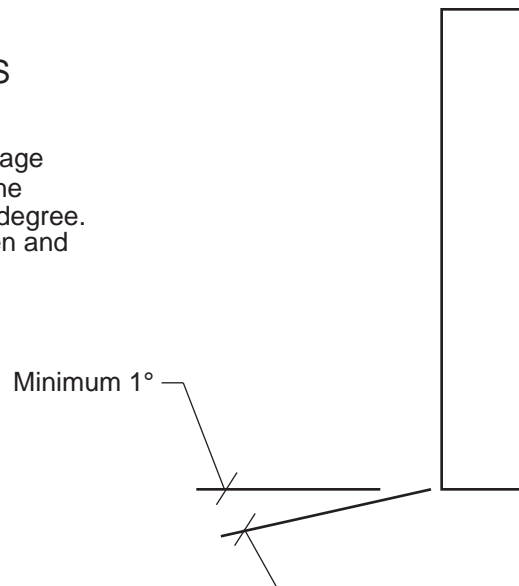

## PREPARATION OF FRAME

All hardware back-up plates are installed in the frame at the factory. All sash materials will have been cut to length and prepped in the factory.

If the doors and frames are from our stock, the transom frames are fabricated for a vertical frame size of 125 1/2". If your opening is smaller, cut the verticals and sash down to the appropriate length; leaving a minimum 1/4" joint at head. The prep for the transom head horizontal should be made using; either: our jig, EZ-Punch, or a small cut-off of the head material.

Attach frame portion of pivots to the frame.  
 Attach closer clips (if concealed overhead closer) and/or shear blocks to jambs.  
 Cut and notch threshold as required for hardware.

Assemble frame, including threshold. For frames with transoms, sash members must slide into jambs and transom bar during assembly on FG3000. Parts will not snap due to tolerance restrictions.

The frame is now ready for installation.

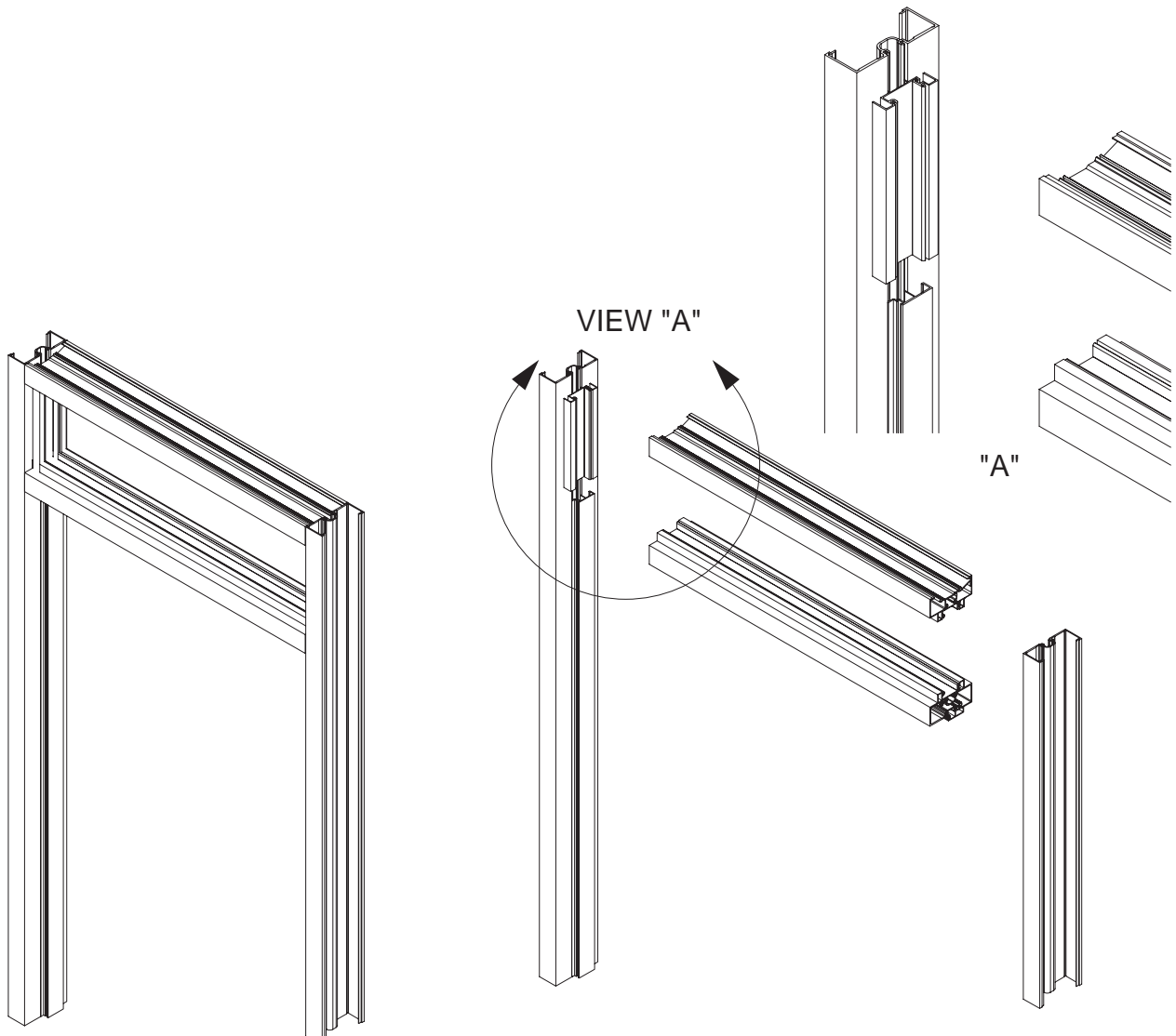

## INSTALLATION OF STANDARD DOOR FRAME

1. Door frame shall be completely assembled, including threshold; with all joints neatly aligned and tight. Be sure all hardware is attached that must be installed prior to frame installation. If flat filler pieces used (recommended), snap them in place.
2. Door frame shall be installed square and plumb (See Figure 1 and 2, below).
3. Level the door frame at the threshold at the high point in the slab. It is preferable to not have a high point in the slab. The door frame is designed to have the jambs run down to the slab.
4. Frame must be securely anchored in place. Solidly shim at all anchor points so as not to bow or distort framing.
5. Mark the concrete through the countersunk holes in threshold.
6. Use masonry bit to drill holes to receive inserts (included).
7. Anchor the threshold to the slab using flat head screws (included).
8. Install door stops (at transom frames).

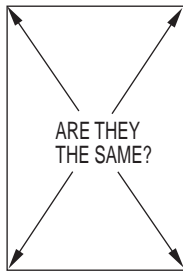

Figure 1

Measure diagonals to check if square.

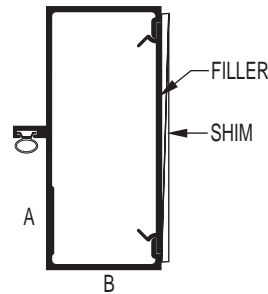
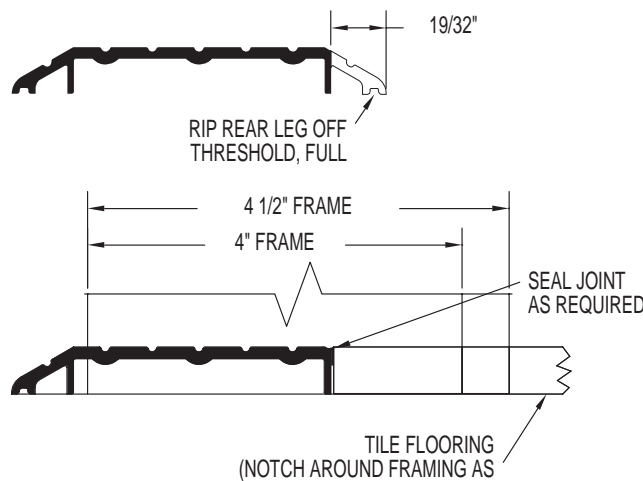

Figure 2

Use 4' level to check if plumb at points A and B.

9. You are now ready to install the door. Proceed to pg. 15 if pre-glazing the door, or pg.17-24 to install door.



INSTALLATION INSTRUCTIONS FOR HIGH-PERFORMANCE THRESHOLD

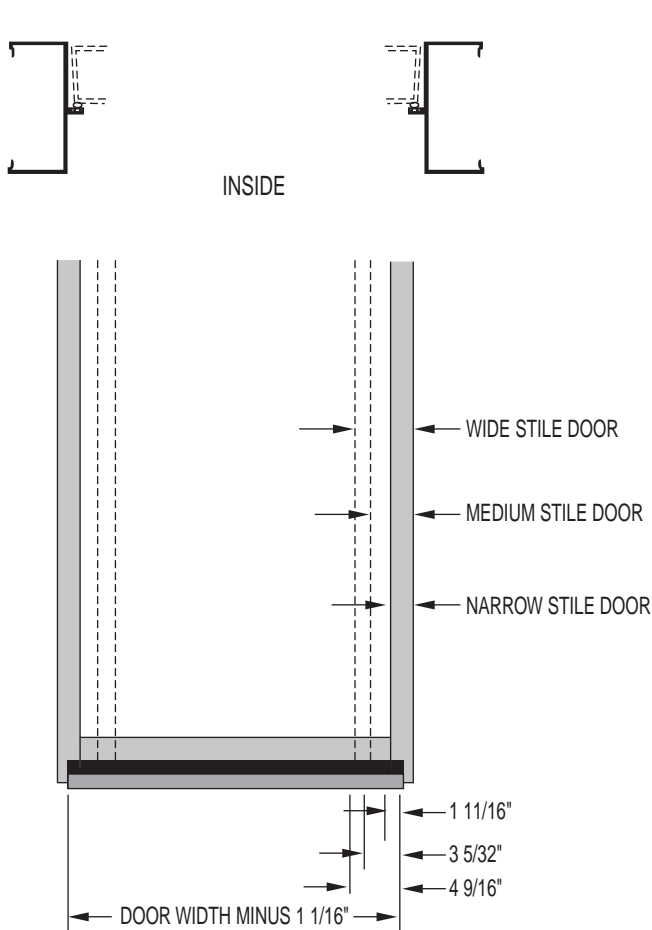

Figure 1

SINGLE BUTT HINGE OR OFFSET PIVOT DOORS

1. Cut the D-118 weather-strip to Door Width minus 1 1/16" see (fig. 1).
2. Placing the D-118 1-1/16" up from the bottom of the door rail (fig. 2), center it by overlapping the stiles equal distances (fig. 1). Using the D-118 as a template, mark the door for the attachment holes. Drill the door for #8 x 1/2" FHSMS, attach the D-118 to the door and insert the D-120 silicone strip. Crimp ends.
3. On both frame jambs drill two #29 (.136" dia.) holes in frame for #FS-256 screws and attach clips to frame (fig 2). Drill one #2 (.211" dia.) hole 1/2" in from each end of the threshold as shown in (fig. 2) and countersink for #12 FHSMS #FS-42. Attach threshold to clips.
4. Seal threshold to frame and surrounding conditions.

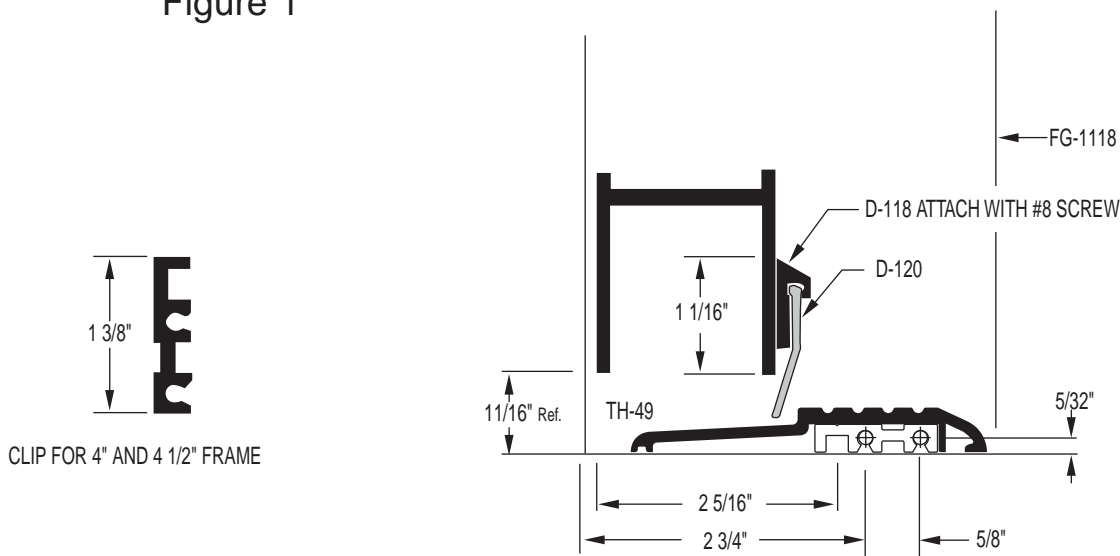
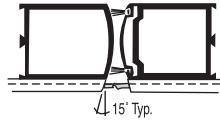
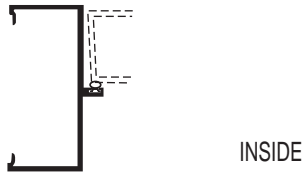

Figure 2

INSTALLATION INSTRUCTIONS FOR HIGH-PERFORMANCE THRESHOLD



PAIR OF DOORS  
BUTT HINGE OR  
OFFSET PIVOT

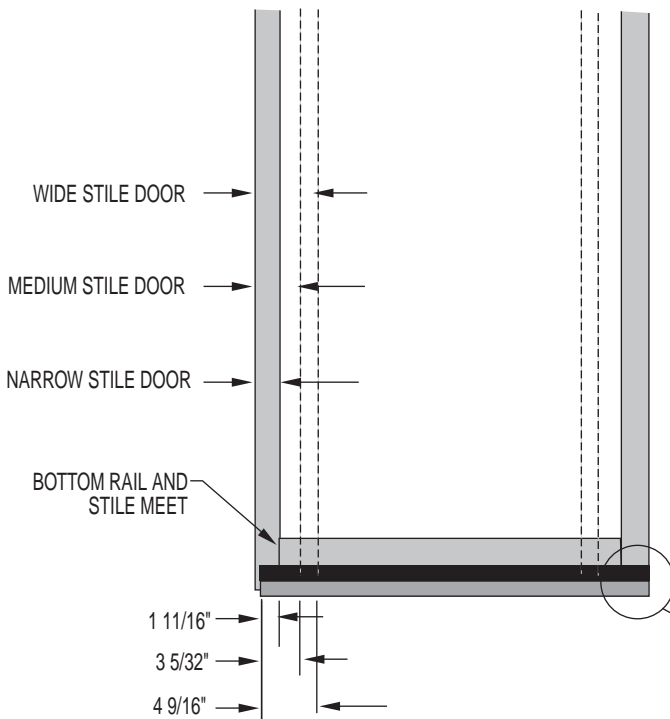

Figure 3

1. Determine door type, mark placement as shown in (fig. 3). Place weather-strip on door and mark for 15 degrees cut as shown in (fig. 4). Cut weather strip.
2. Place weather strip on door 1-1/16" up and mark attachment holes using weather strip as template. Drill for #8 x 1/2" FHSMS and attach weather strip.
3. Install silicone strip allowing over lap as shown in (fig. 4) and crimp pivot end.
4. On both frame jambs drill two #29 (.136" dia.) holes in frame for #FS-256 screws and attach clips to frame (fig 5). Drill one #2 (.211" dia.) hole 1/2" in from each end of the threshold as shown in (fig. 2) and countersink for #12 FHSMS #FS-42. Attach threshold to clips.
5. For doors with concealed rod panics drill holes in threshold as shown in (fig. 6). Be sure to drill into condition below to allow rod to engage into threshold as shown in (fig. 5). Attach #3315 stop.
6. Seal threshold to frame and surrounding conditions.

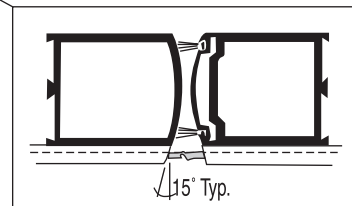

Figure 4

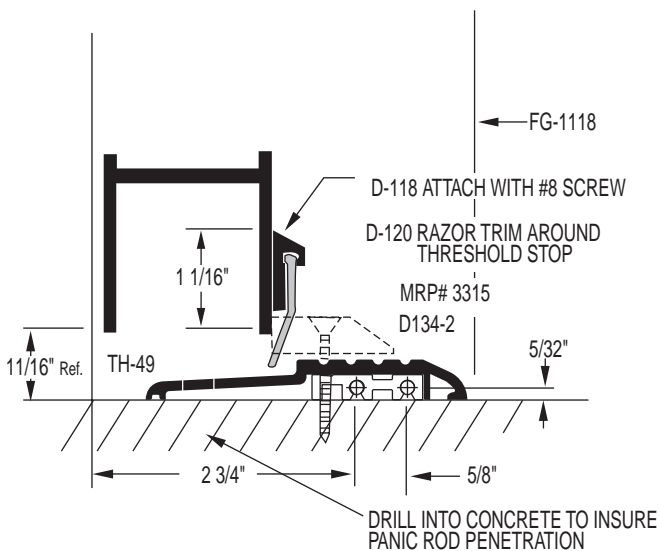

Figure 5

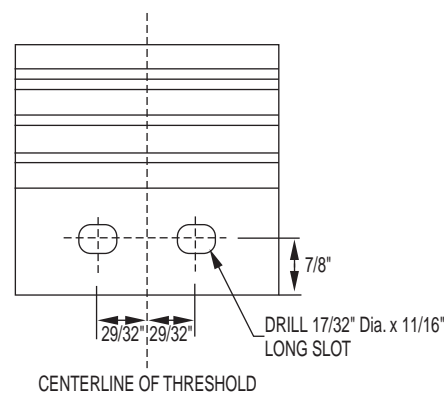
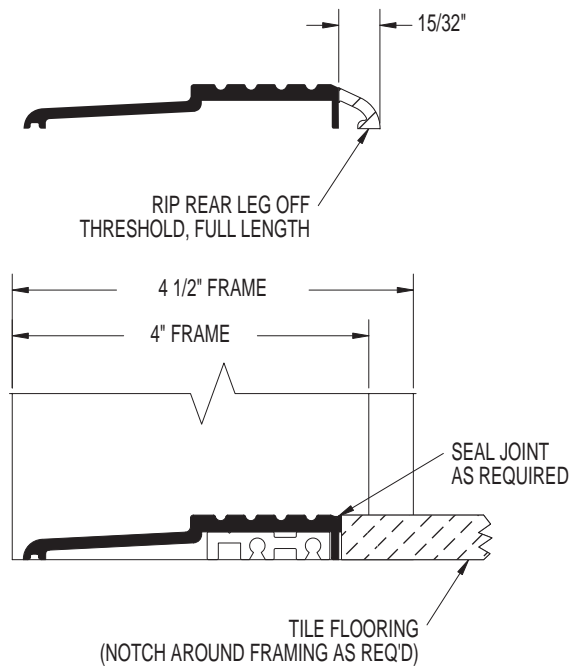

Figure 6

## THRESHOLD MODIFICATION

### THRESHOLD MODIFICATION FOR TILE FLOORING

1. Rip  $15/32$ " off rear leg of threshold, full length of part.
2. Follow standard installation instructions for high performance threshold.
3. Butt flooring to rear of threshold, sealing joint as required. NOTE: Notching of flooring around framing members may be required.



## GLAZING THE DOOR

Glass setting blocks are installed, in their proper locations, in the factory. Glazing prior to installation is possible (step 1). If the decision is made to glaze after the door is installed, skip step 1.

1. Lay door flat across two sawhorses (easiest); or, on protected floor (careful not to damage finish on door).
  2. If glazing door after it is installed, lock door to prevent swinging.
  3. Trim E.P.D.M. glazing gasket flush with ends of glass stops.
  4. Remove glass stops on the side of door that is closest to you.
  5. Turn glass jack in the top rail counter-clockwise until it is in retracted position flush with extrusion.
  6. Be sure that the stops that remain are securely in place.
  7. Place glass on the stops and against the setting blocks. If you are glazing the door in the installed position, it is important to push glass firmly against the glass stops.
  8. Adjust for gaps at the stiles.
  9. Once the glass is in the correct position, screw down the glass jack to top of glass.
  10. Install the glass stops — verticals first at 1/4". Horizontals first at all other glass thickness. (See details below).
- Note: Top stops are notched to clear glass jack. Be sure to hook the stop into the dovetails on the rails and stiles, then snap in place. A mallet may be used to drive stops in place.

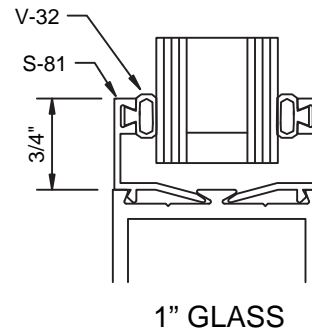
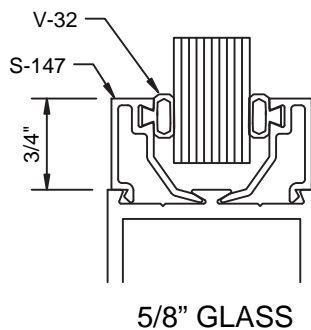
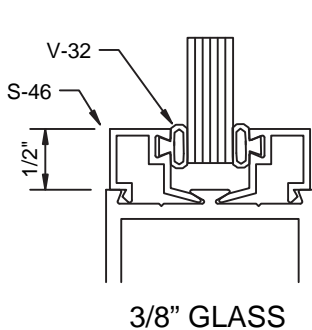
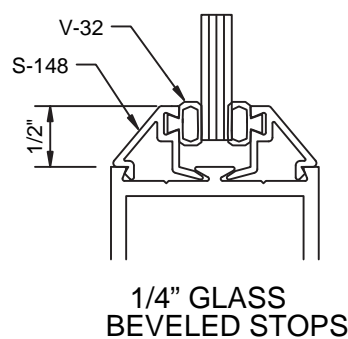
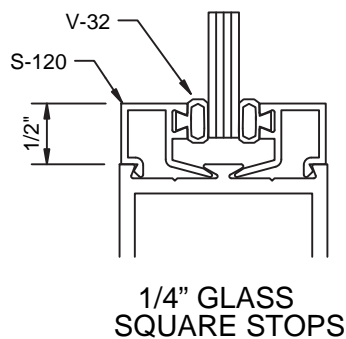

# DOOR & FRAME INSTALLATION MANUAL

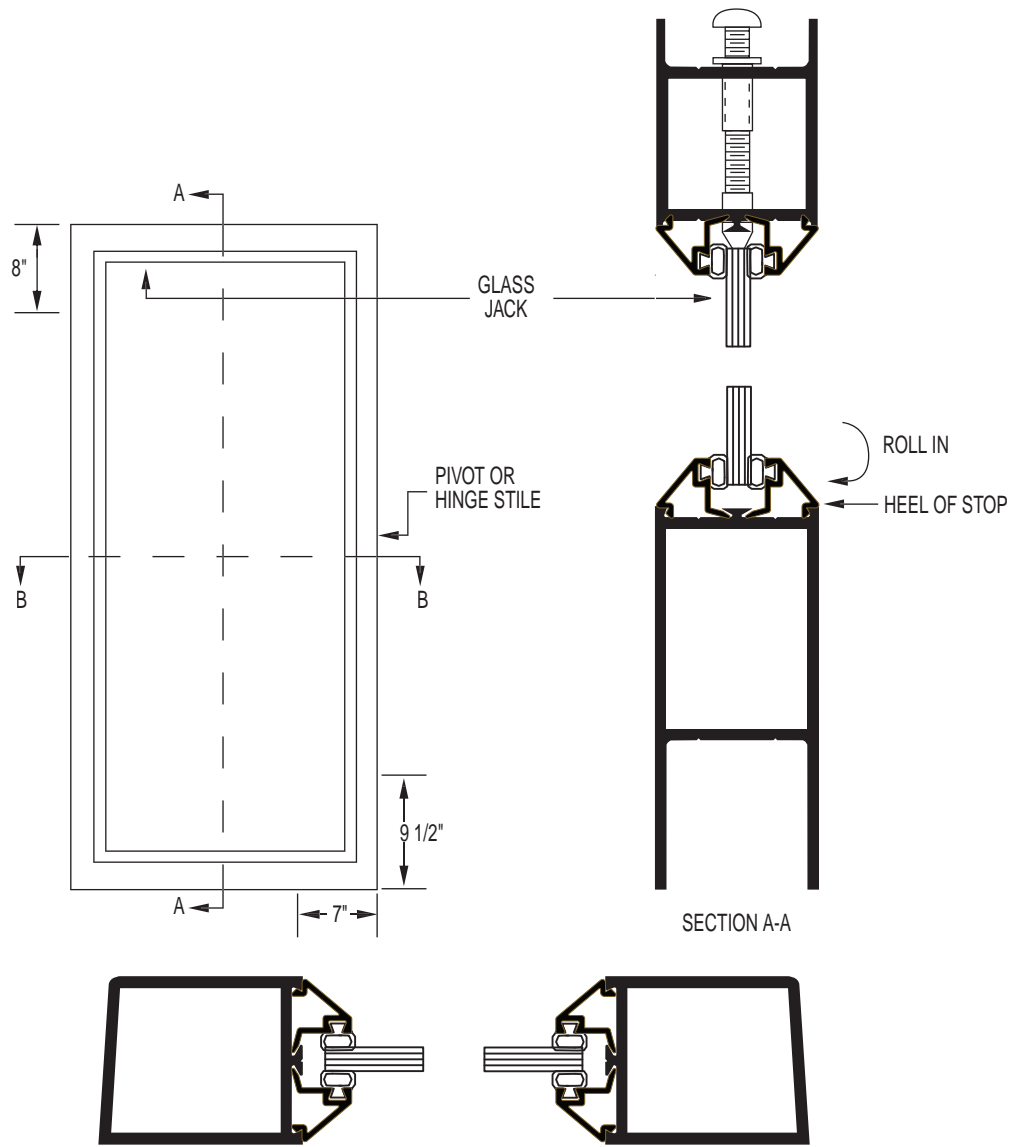

SECTION B-B

NOTE: SETTING BLOCK LOCATIONS MAY VARY BY +/- 1"



## INSTALLATION OF OFFSET HUNG DOOR ON BUTT HINGES

Back-up plates are installed in the door and the frame. Butt hinges should be installed on the door. The door may or may not be glazed prior to installation of door.

1. Lift door upward until butt hinges align with hinge cutout in frame.
2. Block under door when hinge and cutout are aligned.
3. Attach hinges to frame back-up plates using proper screws (included). There is a slight adjustment available if location of door prep and frame cut-out is off slightly. Back off on the screws slightly and adjust door to proper position; then, tighten down screws.
4. Now that the door is hung, it is time for final adjustments and attachment of hardware.  
NOTE: If you have not pre-glazed the door, glaze the door before attachment of hardware.

INSTALLATION OF OFFSET HUNG DOOR ON BUTT HINGES

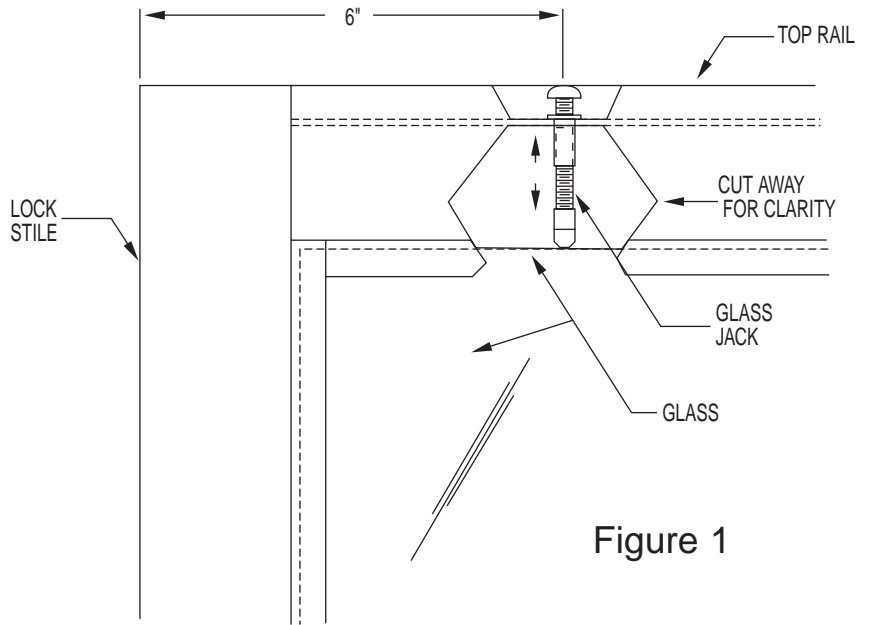
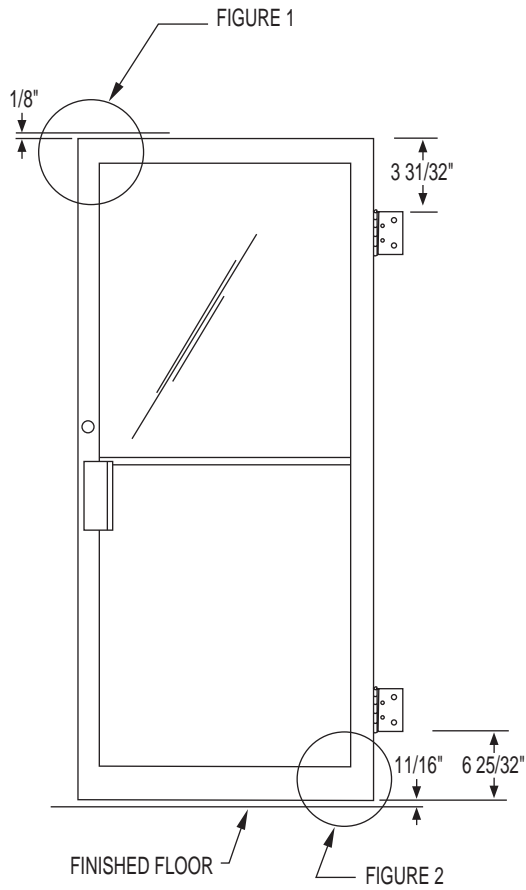
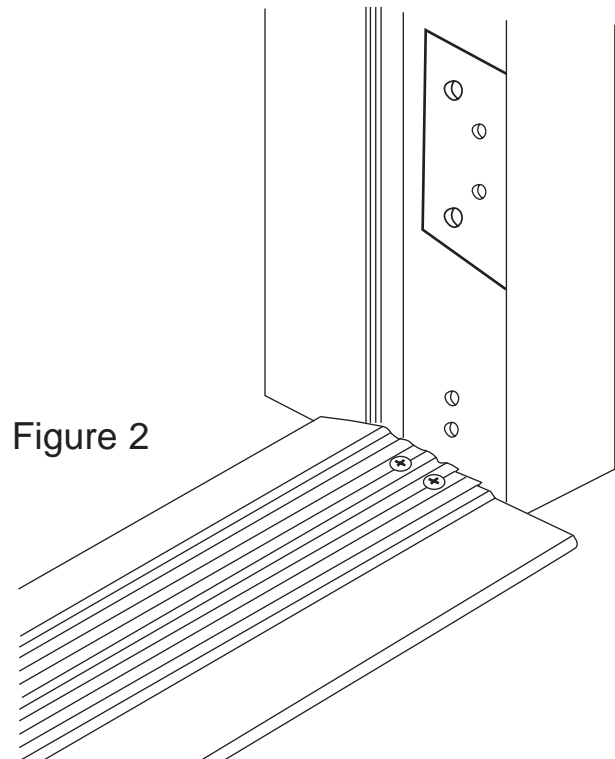

Figure 1



## INSTALLATION OF OFFSET HUNG DOOR ON PIVOTS

Back-up plates are installed in the door and the frame where required. Frame portion of pivots should be on the frame and door portion of pivots should be installed on the door. The door may or may not be glazed prior to installation of door.

1. Lift door upward and tilt in open position. Place door portion of bottom pivot on frame portion of bottom pivot.  
(See illustration)
2. Depress the pivot pin in the door portion of the top pivot.
3. Slide door portion of top pivot under the frame top pivot.
4. Jiggle door until the pivot pin slides into the frame top pivot.  
NOTE: To remove door, take the 3 screws out of the frame portion of top pivot and let drop. Then, tip door out of frame.
5. Now that the door is hung, it is time for final adjustments and attachment of hardware.  
NOTE: If you have not pre-glazed the door, glaze the door before attachment of hardware.

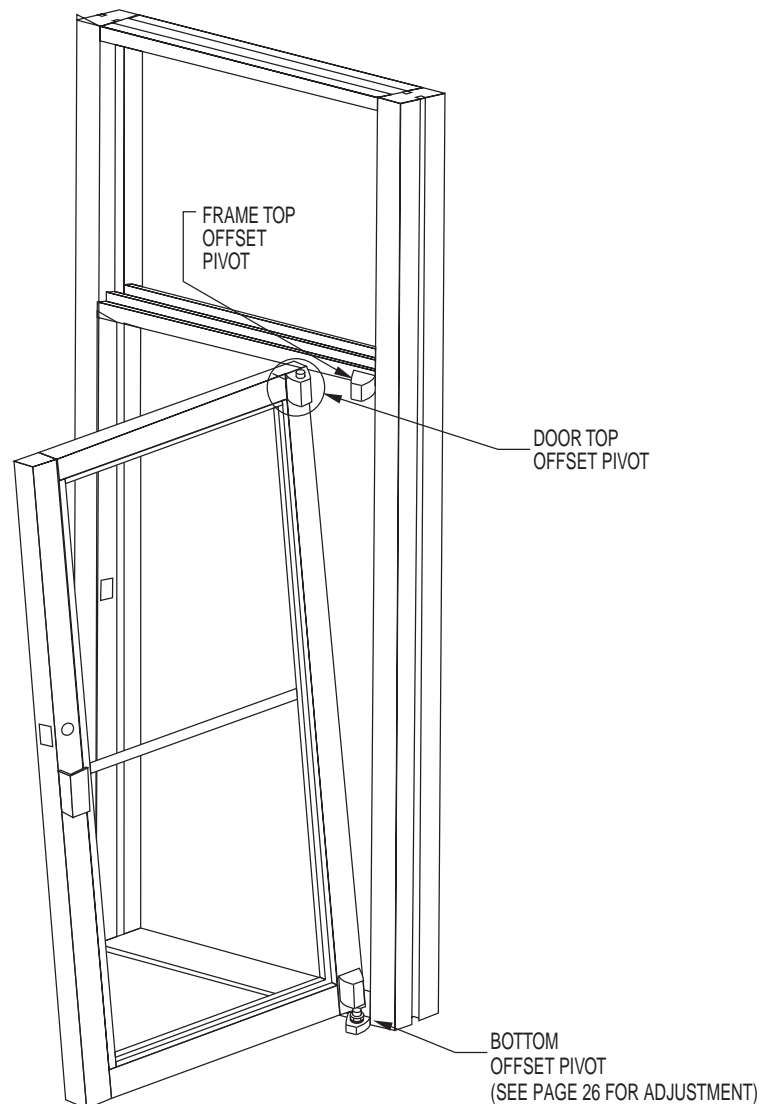

## INSTALLATION OF OFFSET HUNG DOOR WITH STANDARD OVERHEAD CLOSERS

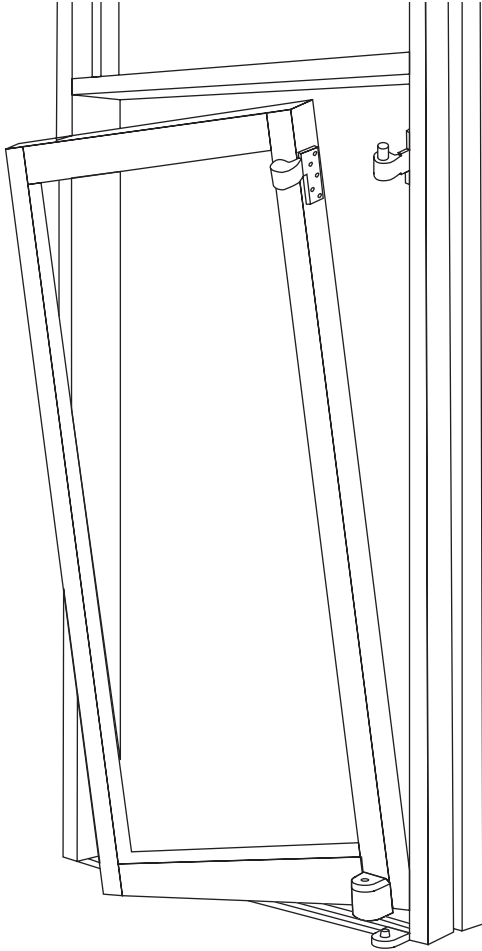

1. Set door in frame so that door portion of the bottom pivot is over spindle of frame portion of the pivot.
2. Align door portion of OP-11 above frame portion and lower door until positive engagement is felt.  
NOTE: the bottom pivot is pre-adjusted to provide 3/16" clearance between door top rail and frame transom bar. For further vertical adjustment see figure 2 on page 27.
3. When door is properly positioned, secure closer to door and transom bar per instructions provided with closer. These closers require the use of offset arms. CAUTION: Smooth, permanent trouble-free operation of the door depends on the proper installation of the closer. A print is furnished in each closer package to give correct installation procedure.
4. Close door, glaze and adjust as outlined on pages 15 and 27.

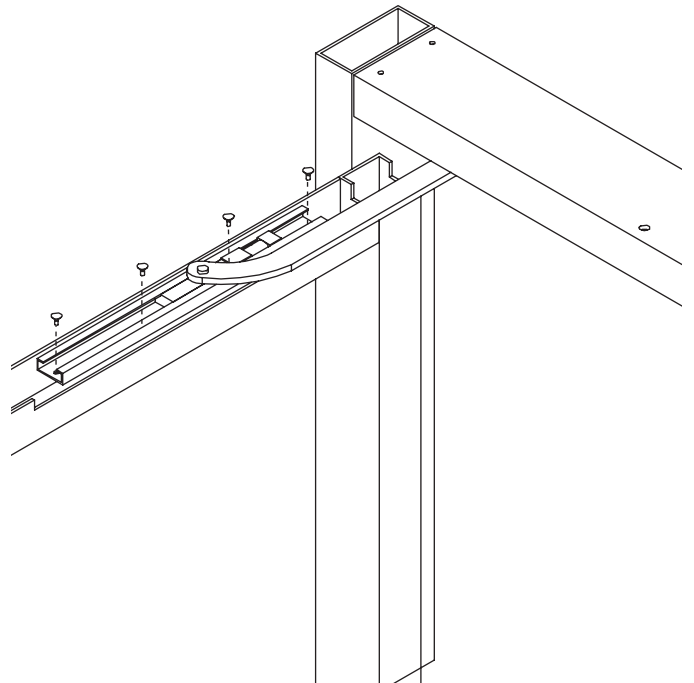
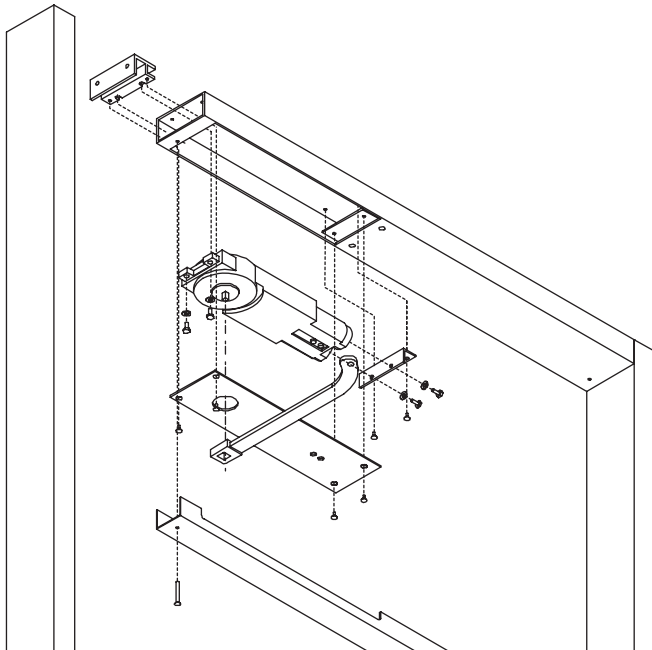

## INSTALLATION OF CENTER HUNG DOOR WITH STANDARD CONCEALED CLOSER

1. With closer mounted in transom, (see Frame instructions) make sure it is in hold-open position. When closer has no hold-open feature, the following "dogging" method applies:
  - A. Rotate closer spindle to 90° (either R.H. or L.H.) with a wrench for door installation, or rotate with door, when removing closer from existing installation.
  - B. Insert suitable 5/32" diameter hard pin or nail through 3/16" hole in base plate (located on direct line between pivot and pivot jamb) (See fig. 1)
  - C. The pin should go through base plate, lower bushing plate at closer and hole in dogging cam (some back and forth movement of door or wrench may be necessary to locate this hole. The pin should be inserted at least 1 1/2" into closer.
  - D. Holding the pin in place, release door or wrench gently. Closer will be held at 90°.

2. Lift door onto floor pivot making sure of pin engagement. Place door upright in the 90° open position corresponding to the position of the indicator mark on the closer shaft.
3. Push top arm of door against closer shaft.
4. Apply top clamping block per label at top of door, with two socket head cap screws using 7/32" hex key, but do not tighten (See fig. 2).

NOTE: If vertical adjustment of the door is required, use a wrench to turn bottom pivot adjusting screw up or down (See fig. 3).

CAUTION: Make sure top clamping block screws are loose before making adjustment.

5. Return to top clamping block and TIGHTEN socket head cap screws SECURELY and EVENLY per the torque label on the top corner of door.
 

CAUTION: Be sure to remove pin before trying to operate closer. To remove pin, open closer from dogged position slightly to remove spring force from pin. Remove pin and gently release closer.
6. Insert weathered end trim cap at top and secure to door with screw.
7. To operate, push door out of hold open position. (If model has no hold open, remove dogging pin and gently release closer.)
8. Glaze door. (See page 15)
9. Check top arm centering screws for snug contact with the sides of the top rail.
 

CAUTION: Over-tightening will bulge the top rail. Check tightness of arm anchoring screws. If the door does not center in the frame after being operated a few times, loosen the top arm anchor screws, readjust the centering screws (do not bulge sides of top rail) and retighten the anchor screws.
10. Adjust closer closing speeds and latching speeds. (See Adjustment Instructions packed with Closer.)

Figure 1

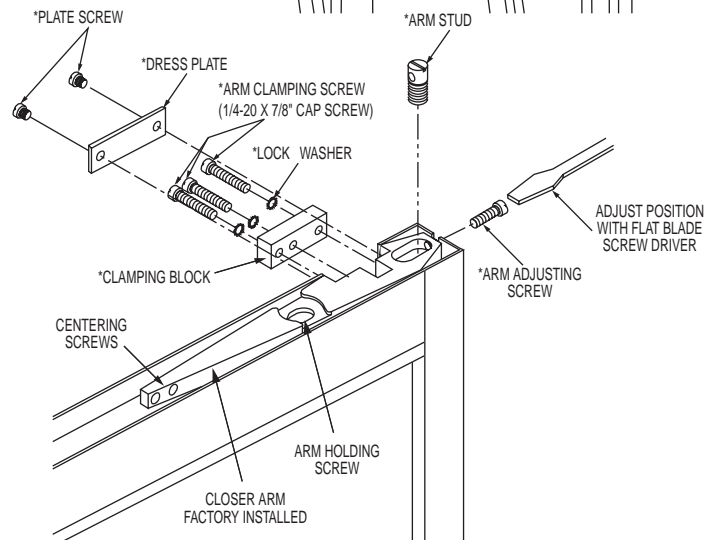
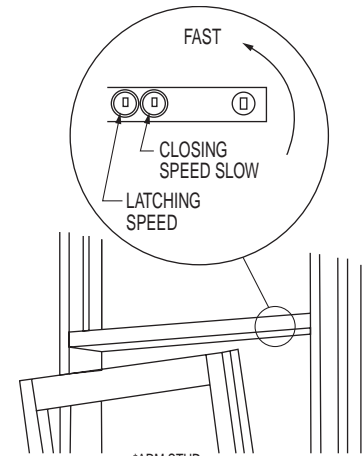

Figure 2

Adjust door by turning adjusting screw clockwise to lower door or counterclockwise to raise door. When proper setting is achieved tighten top arm attachment screws.

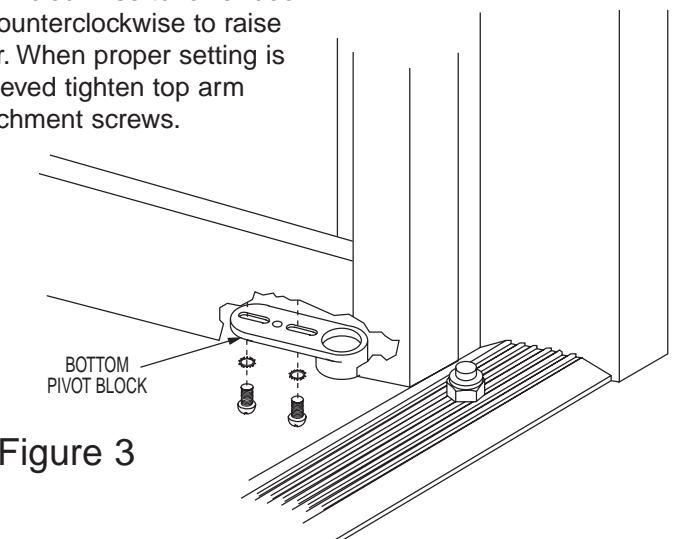
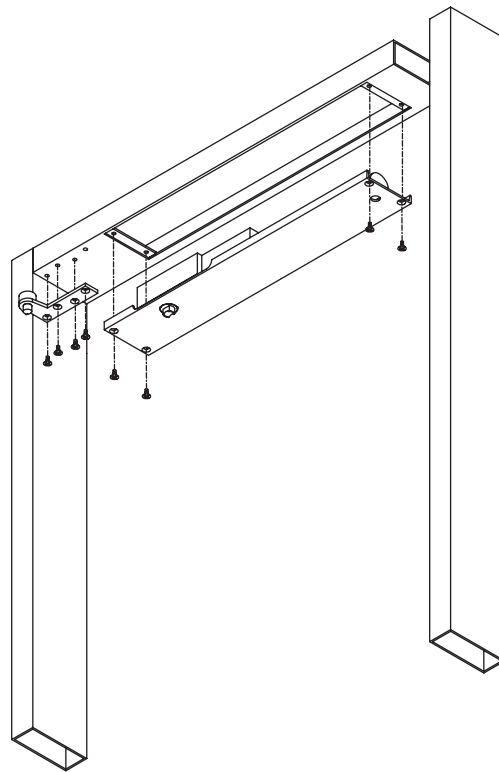
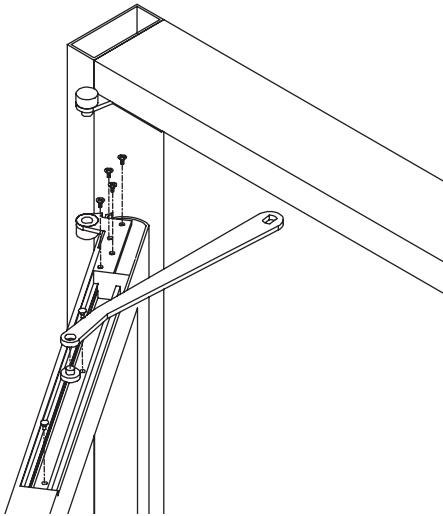

Figure 3

## INSTALLATION OF OFFSET HUNG DOOR WITH LCN CONCEALED OVERHEAD CLOSER

Back-up plates are installed in the door and the frame. Track ships with closer. Frame portion of pivots should be on the frame and door portion of pivots should be installed on the door. The door may or may not be glazed prior to installation of door.

1. Lift door upward and tilt in open position. Place door portion of bottom pivot on frame portion of bottom pivot.
2. Align door and frame portions of top pivot
3. Clip spindle of closer into track.
4. Attach arm to spindle.
5. Operate door a couple of times.
6. Check clearances at both jambs. should be 3/32" between stiles and jamb.



## INSTALLATION OF CENTER HUNG DOOR WITH LCN CONCEALED CLOSER

Back-up plates are installed in the door and the frame. Track ships with closer. Frame portion of (CP150) pivots should be on the frame and door portion of pivots should be installed on the door. The door may or may not be glazed prior to installation of door.

1. Lift door upward and tilt in open position. Place door portion of bottom pivot on frame portion of bottom pivot.
2. Align door and frame portions of top pivot
3. Clip spindle of closer into track.
4. Operate door a couple of times.
5. Check clearances at both jambs. should be 3/32" between stiles and jamb.

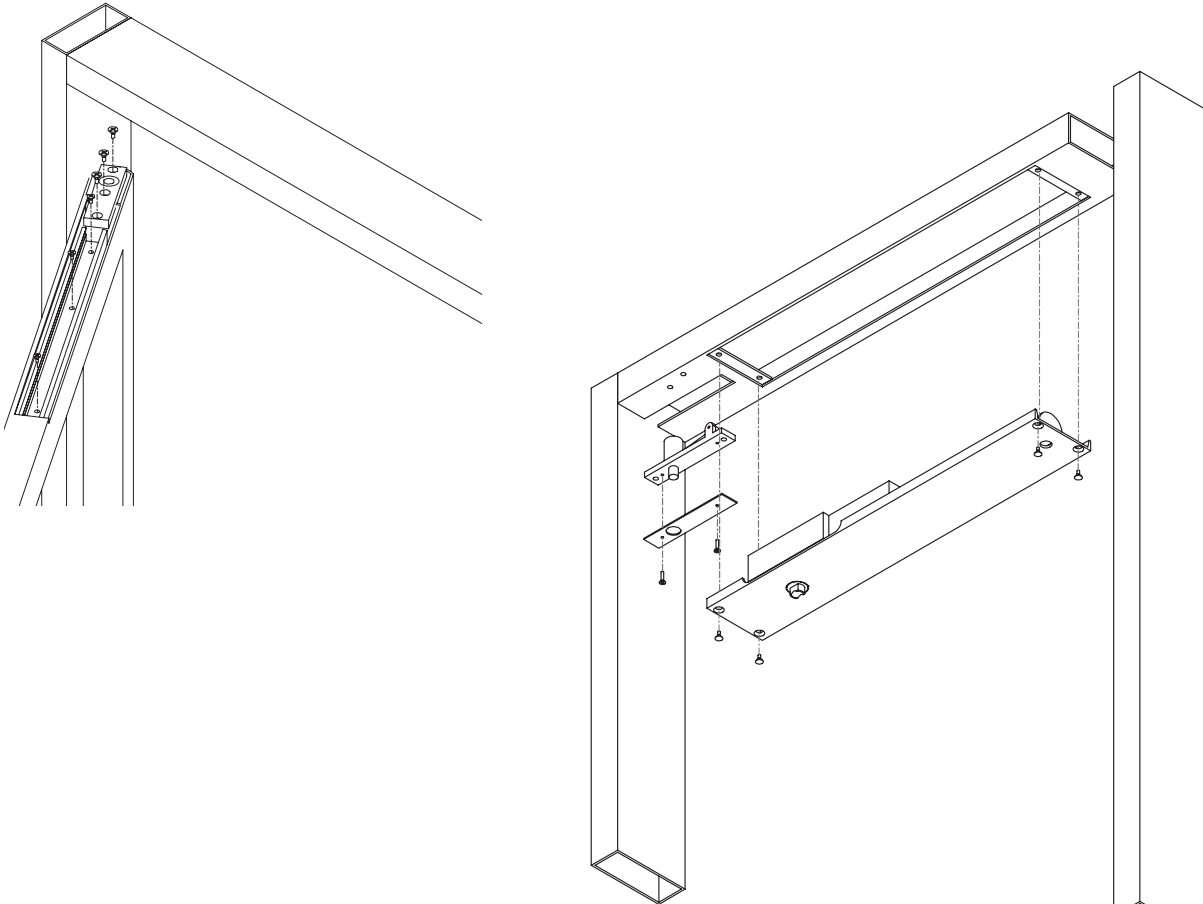

## INSTALLATION OF OFFSET HUNG DOOR WITH FLOOR CLOSER

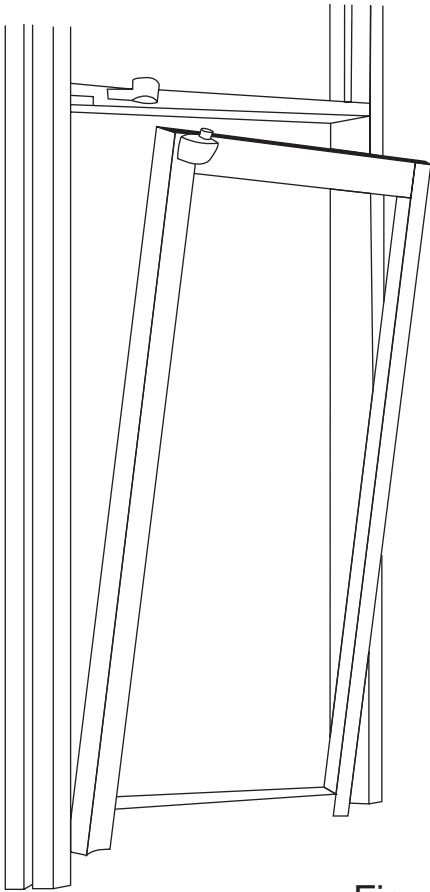

Figure 1

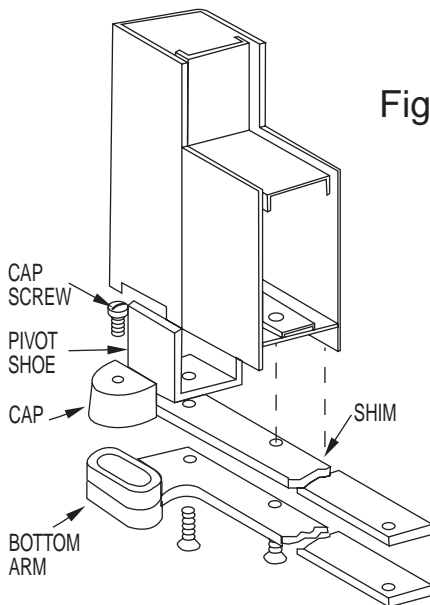

Figure 2

1. Position floor closer using Closer Instruction Template.  
CAUTION: Smooth, permanent trouble-free operation of the door depends on the proper installation of the closer. A Template is furnished in each floor closer package to give correct position of center of closer spindle from door and frame, as well as the proper height for use with or without thresholds.
2. Modify cut-out in door as necessary. (fig. 3 or Closer Template)
3. Fasten bottom arm into door bottom rail.  
Assemble pivot shoe, shim (when used) and bottom arm as shown in figure 2. The 3/8" Shim furnished will satisfy the requirements of most closers with thresholds. In some cases, other thicknesses will be required and must be made by installer.  
NOTE: Shoe is drilled right hand and left hand. If threshold is not to be used, do not install shim.
4. Place frame portion of top pivot in transom bar and secure in place using 3 screws #12-24 x 5/8" M.S.
5. Set door in frame so that bottom arm engages spindle of floor closer. Do not tighten locking screw.
6. Depress pin in top door portion pivot and slip under frame portion until positive engagement is felt. Tighten closer arm per instructions.
7. Shim closer cement case so that there is 1/8" setback between exterior face of frame and face of door and 3/32" clearance between vertical door stiles and frame jambs. Work to 1/8" between pairs of doors.
8. Adjust vertical clearance to 1/8" between door top rail and transom bar with adjusting screws or shims as provided in closer package.
9. When closer is properly positioned, fill space under and around cement case in rough opening with grout or quick set cement. (Plaster of Paris is not recommended.)
10. Close door, glaze and adjust as outlined on pages 15 and 25.

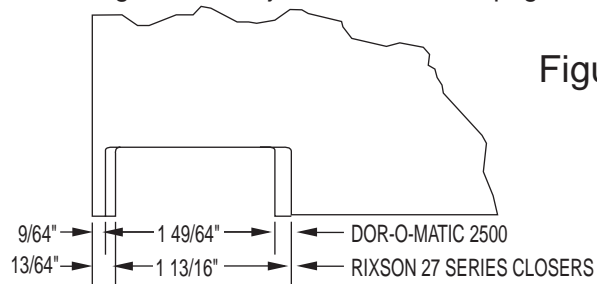

Figure 3



FINAL ADJUSTMENTS TO DOOR

After door is installed, check clearances. The top rail should be consistently 1/8" below the header. The bottom of the door should be consistently 3/16" above the threshold. The gap between door and jambs should be 3/32" from top to bottom.

If the gap between the top rail and header is showing too large at top of the lock stile, loosen glass jack and lift up on door until gap is corrected. Tighten down glass jack to top of glass. See FIGURE 1

DO NOT raise door by only tightening the glass jack against the glass. Glass breakage could occur.

On pairs, adjust screws in adjustable astragal to keep a consistent 1/8" gap between door leaves.

On butt hung doors, butts may be shimmed out to adjust clearance where there is too much gap at the lock stile.

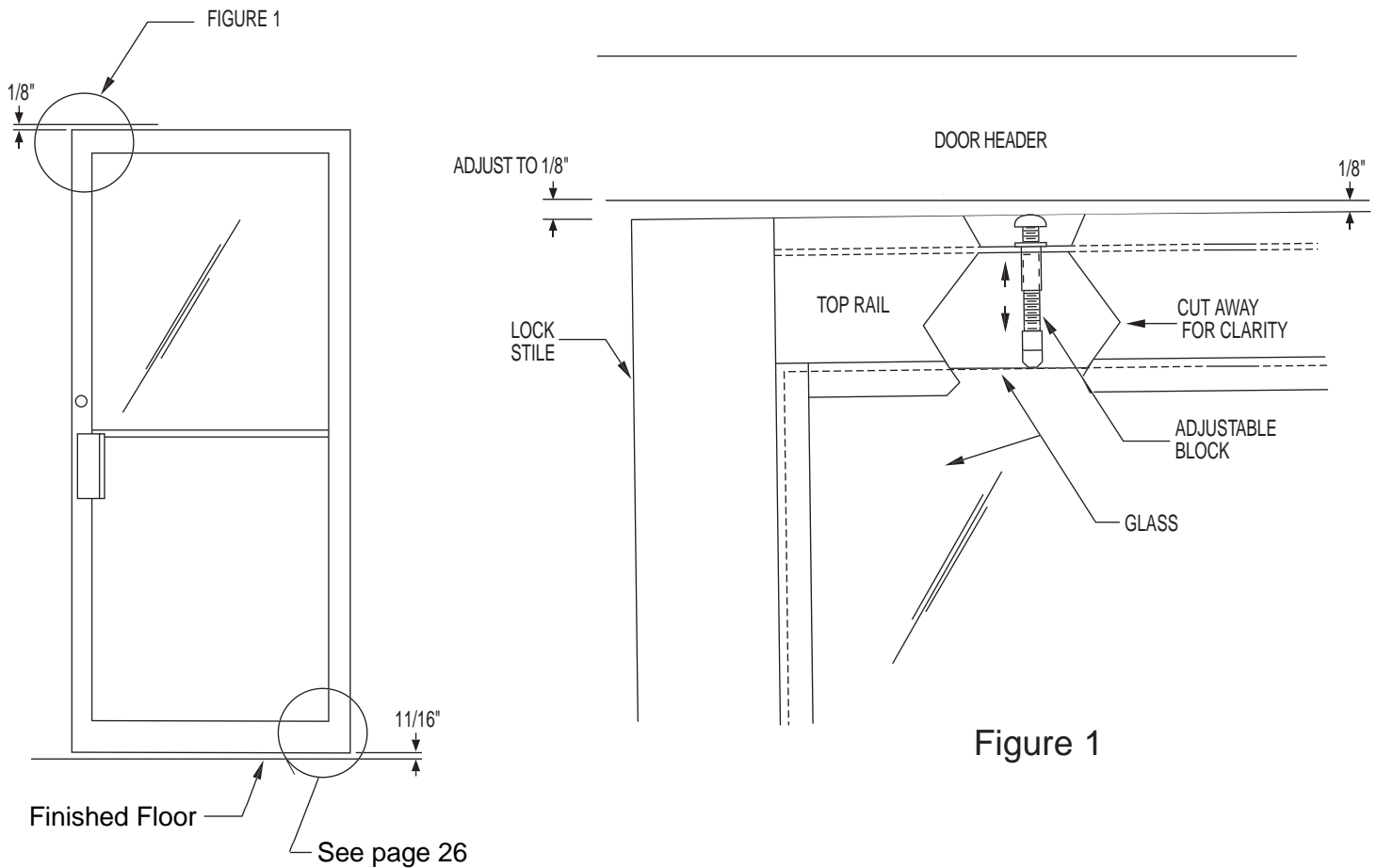

## FINAL ADJUSTMENTS TO DOOR

On offset pivot doors:

- 1) Open doors and turn bottom pivot support screws down until they contact the slab. Do not over-drive the screws because of additional stress being placed on pivot. See FIGURE 2
- 2) If top of door on hinge side is not 1/8" below the frame, remove adjustment screw cover (See FIGURE 3), insert allen wrench into top side of pivot and adjust as necessary. Screw will be turned clockwise to raise door and counterclockwise to lower. See FIGURE 4
- 3) If door opening is out more than adjustable pivot can adjust. Loosen set screw on bottom frame pivot, raise secondary adjustment screw then tighten set screw back in place. See FIGURE 2. Repeat step 2 as required.

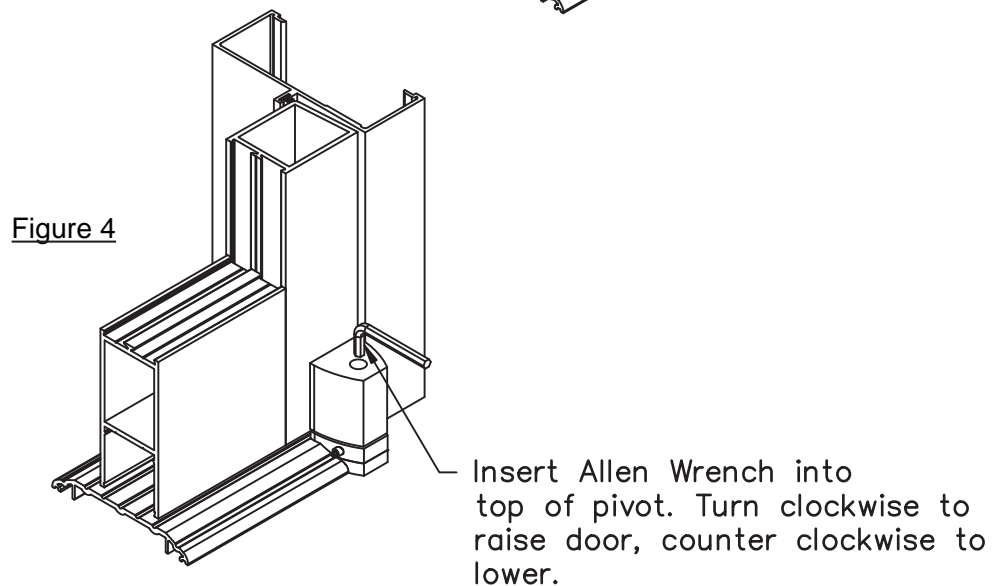
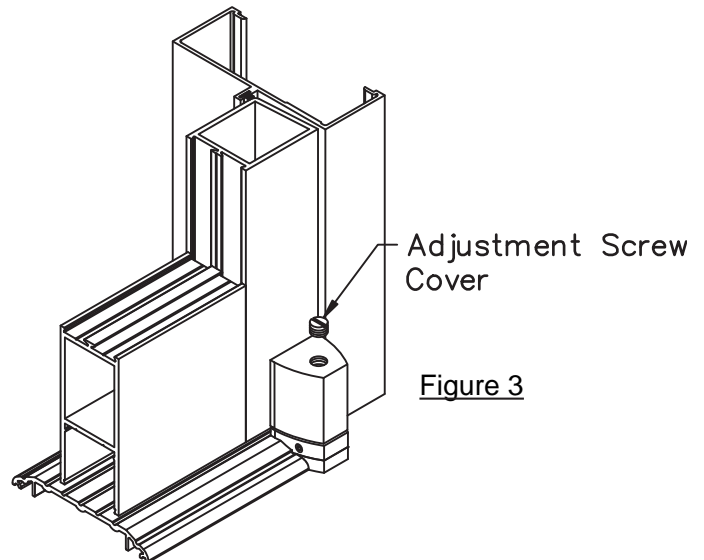
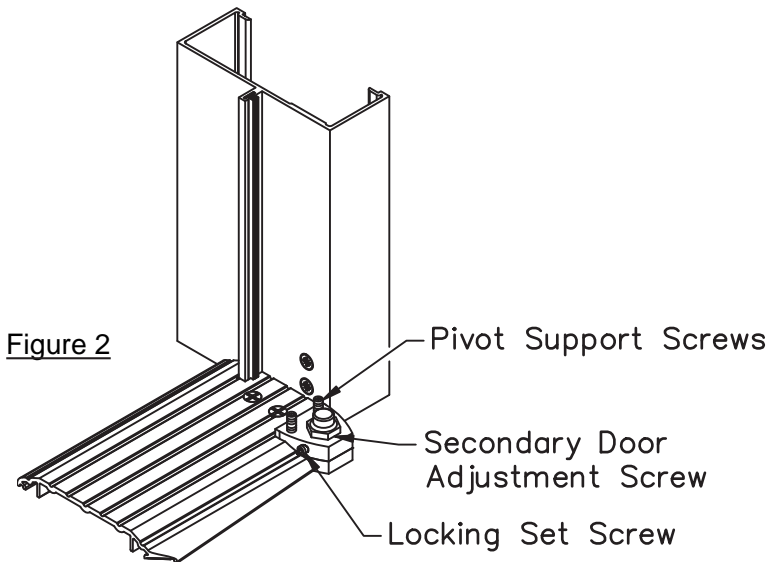

## ATTACHMENT OF AND ADJUSTMENTS TO HARDWARE

### CLOSER

Refer to instructions that are sent in the boxes for installation of the following items, unless noted otherwise:

#### Surface

Norton 1600 Series

LCN 4040 Series

LCN Quest — Peel-off templates and instructions are sent in box.

#### Concealed

Jackson 20-330

LCN 2030

Dorma RTS-88

#### Floor

Rixson 27 (Offset Hung)

Rixson 28 (Center Hung)

Dorma BTS-80

### EXIT DEVICE (PANIC) — Rim

(RP-100)

### EXIT DEVICES — Concealed Rod

(CP-100)

(VIP-1) Installed in door at factory

(VIP-2)

### DOOR SWEEP

#### V-231

Cut to length for door.

Apply 2-sided tape to back of part.

Peel protective sheet off.

Place in position at bottom of door.

Drill pilot holes through holes in V-231 into door.

Fasten with screws supplied.

## STANDARD PUSH BAR INSTALLATION

PB-21 Push Bar will be shipped with screws for attachment. Holes are pre-drilled in the factory.

Where PB-21 is not used with PH-20:

- Step 1: Lay out the parts to be sure they are all there.
- Step 2: Place washer on 1/4" diameter through-bolts.
- Step 3: Align PB-21 with holes in door stiles.
- Step 4: Insert through-bolts into holes in stile from exterior of door.
- Step 5: Tighten through-bolts into push bar.

Where PB-21 is used with PH-20:

- Step 1: Lay out the parts to be sure they are all there.
- Step 2: Align Pull with top hole on exterior of door.
- Step 3: Insert through-bolt stud in top hole from interior into pull.
- Step 4: Loosen setscrews in PB-21.
- Step 5: Place PB-21 over stud on lock stile and align with hole in hinge stile.
- Step 6: Place washer on 1/4" diameter through-bolts.
- Step 7: Insert through-bolt from exterior into PB-21 at hinge stile.
- Step 8: Tighten setscrews into stud on lock stile.

Wire Push Bar Replacement for PB-11 shipped with studs for use in pre-existing riv-nuts.

- Step 1: Lay out the parts to be sure they are all there.
- Step 2: Remove PB-11 and bracket.
- Step 3: Install studs into existing riv-nuts.
- Step 4: Back out setscrews in replacement push.
- Step 5: Align replacement push over studs.
- Step 6: Tighten setscrews.

## STANDARD PULL HANDLE INSTALLATION

PH-20 Pull Handle will be shipped with screws for attachment. Holes are pre-drilled in the stiles at the factory.

Where PH-20 is not used with PB-21 (PH-20TB):

- Step 1: Lay out the parts to be sure they are all there.
- Step 2: Place washers over through-bolts.
- Step 3: Align pull with holes in door stile.
- Step 4: Insert through-bolts into holes in stiles from exterior of door.
- Step 5: Tighten bolts into pull.

Where PH-20 is used with PB-21 (PH-20/PB-21):

- Step 1: Lay out the parts to be sure they are all there.
- Step 2: Align PH-20 with top hole on exterior of door.
- Step 3: Insert through-bolt stud from interior of door through top hole into PH-20.
- Step 4: Place washer on 1/4" diameter through-bolts.
- Step 5: Insert through-bolt from interior through bottom hole into PH-20.

PH-20BTB back-to-back pulls:

- Step 1: Lay out the parts to be sure they are all there.
- Step 2: Align pull with holes on exterior of door.
- Step 3: Insert through-bolt stud from interior of door through top hole into pull.
- Step 4: Insert through-bolt stud from interior of door through bottom hole into pull.
- Step 5: Loosen setscrews in push.
- Step 6: Place push over studs and tighten setscrews.

Wire Pull Replacement for PH-10 shipped with studs for use in pre-existing riv-nuts.

- Step 1: Lay out the parts to be sure they are all there.
- Step 2: Remove existing PH-10.
- Step 3: Install studs into existing riv-nuts.
- Step 4: Back out setscrews in replacement pull handle.
- Step 5: Align replacement pull handle over studs.
- Step 6: Tighten setscrews.

## MAINTENANCE RECOMMENDATIONS

- Every 3-4 weeks, the following items should be lubricated with STP Spray Silicone to insure the hardware functions properly:
  1. Door and Frame Pivots
  2. Lock Cylinders
  3. Exit Device (Panic) Hardware (fig. 3 pg. 31)
  4. Closer Arm
- The following items need to be checked regarding the door closer:
  1. Check/Adjust the Sweep Range, Latch Range, and the Back Check. This adjustment is made by turning the Valves on the end of the closer. The "S" valve = Sweep, the "L" valve = Latch, and the "BC" valve = Back Check.
  2. Check and tighten all loose screws on the closer arm and closer unit.
- Proper clearances are essential for proper operation of doors installed. Reference the installation of door and exit device (panic) hardware installation instructions.
- Chemicals used to melt ice should not come in contact with aluminum threshold, bottom of door jambs or pivot hardware. These chemicals are very corrosive and may cause door failure and possible personal injury.

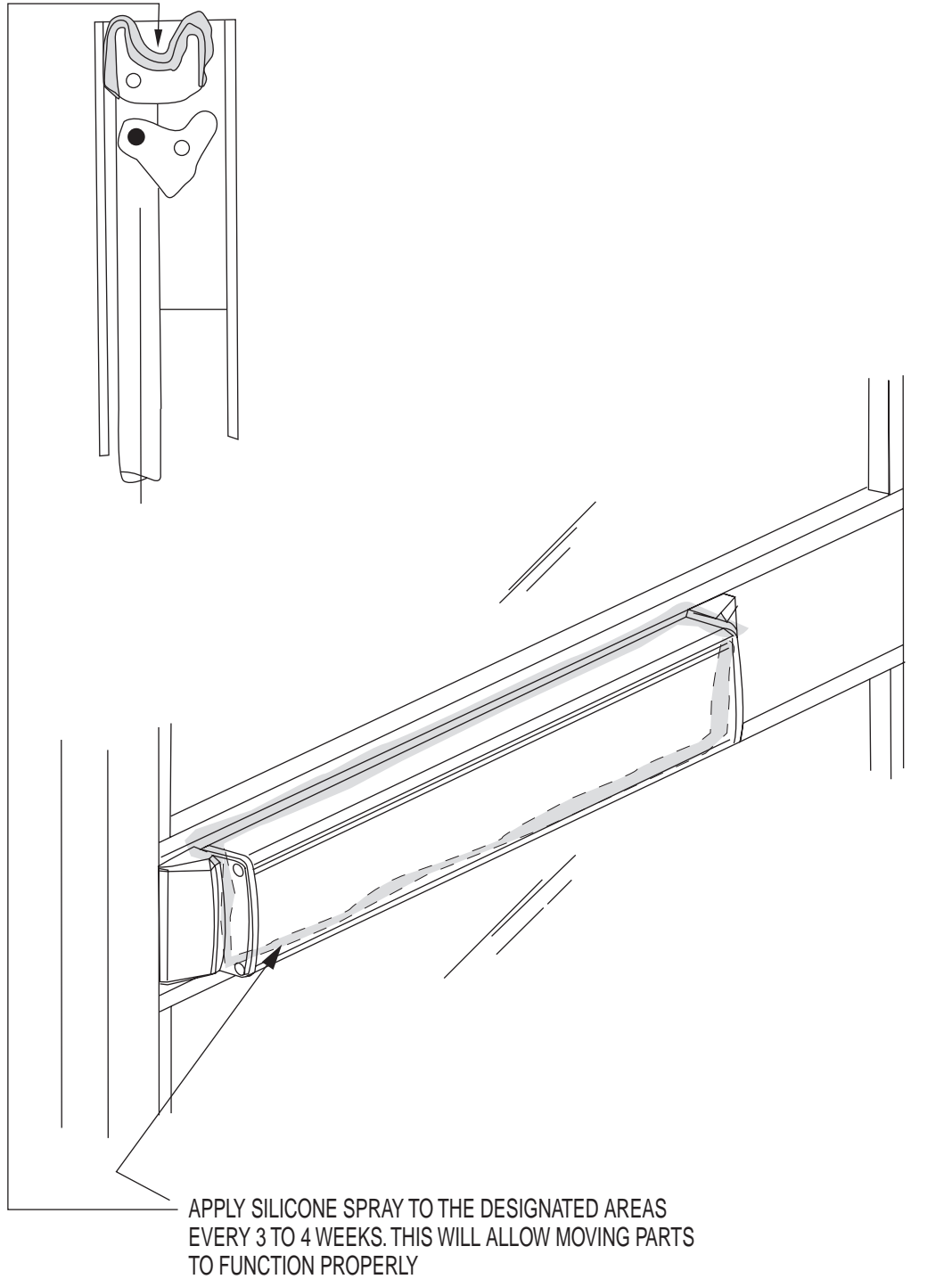

Figure 3